

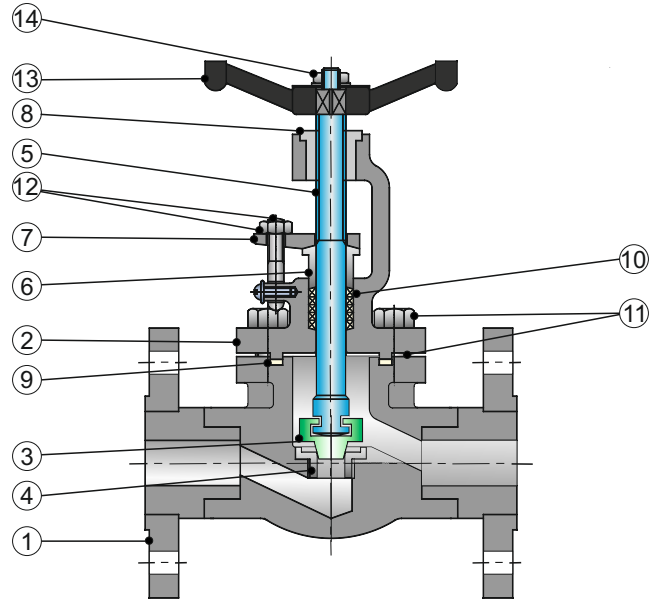

TYPE LGLF - 250

DESIGN FEATURES:

- Manufacturing Std. : API 602 / BS 5352
- Testing & Inspection Std. : API 598 / BS 6755
- Face to Face & End to End : ASME B16.10
- End Flange Dimension : ASME B16.5
- Class : #150, #300 & #600
- Size Range : 15mm to 50mm



MATERIALS OF CONSTRUCTION

Part No.	Description	Material	Qty.
1	Body	ASTM A105, ASTM A182 Gr. F11 / F22 / F304 / F316	01
2	Bonnet	ASTM A105, ASTM A182 Gr. F11 / F22 / F304 / F316	01
3	Disc	AISI 410 (13% Cr.) / 304 / 316	01
4	Seat Ring	AISI 410 (13% Cr.) / 304 / 316	02
5	Stem	AISI 410 (13% Cr.) / 304 / 316	01
6	Gland	AISI 410 (13% Cr.) / 304 / 316	01
7	Gland Flange	ASTM A105, ASTM A216 Gr. WCB, ASTM A182 Gr. F304	01
8	Stem Nut	AISI 410, A351 CF8/CF8M/CF3/CF3M	01
9	Bonnet Gasket	Spiral Wound Graphite	01
10	Gland Packing	Braided & Die Formed Graphite Ring, PTFE Ring	Req.
11	Bonnet Stud & Nut	ASTM A193 Gr.B7 & ASTM A194 Gr.2H	04
12	Eye Bolt & Nut	ASTM A193 Gr.B7 & ASTM A194 Gr.2H	02 Set
13	Hand Wheel	ASTM A216 Gr. WCB, Cast Iron	01
14	Hand Wheel Nut	ASTM A216 Gr. WCB, Cast Iron	01

NOTE:

Due to continuous development higher class and sizes will be available upon request