

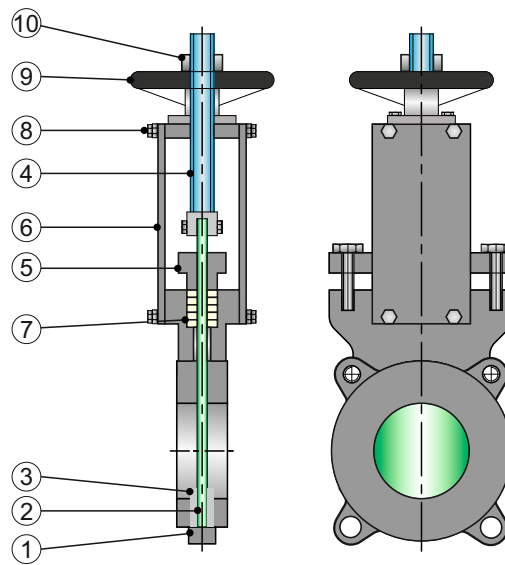

TYPE LKGC - 225

DESIGN FEATURES:

- Manufacturing Std. : API 6D / BS 5351 / MSS SP - 81
- Testing & Inspection Std. : API 598 / BS 6755 / MSS SP - 81
- End Flange Dimension : ASME B16.5
- Face to face & End to End : ASME B16.10 / DIN 3230
- Pressure Rating : ASME B16.34
- Operation : Manual, Gear & Actuator
- Class : #150, #300, #600, #900, & #1500
- Size Range : 40mm to 600mm



MATERIALS OF CONSTRUCTION

Part No.	Description	Material	Qty.
1	Body	ASTM A216 Gr. WCB, A351 CF8/CF8M, Cast Iron	01
2	Disc	AISI 410 (13% Cr.), A351 CF8/CF8M/CF3/CF3M	01
3	Seat	AISI 410 (13% Cr.), A351 CF8/CF8M/CF3/CF3M	02
4	Stem	AISI 410 (13% Cr.), A351 CF8/CF8M/CF3/CF3M	01
5	Gland	ASTM A216 Gr. WCB, A351 CF8/CF8M, Cast Iron	01
6	Yoke Sleeve	ASTM A216 Gr. WCB, Cast Iron	01
7	Gland Packing	Braided & Die Formed Graphite Ring, PTFE Ring	Req.
8	Bolt & Nut	ASTM A193 Gr.B7 & ASTM A194 Gr.2H	Req.
9	Hand Wheel	ASTM A216 Gr. WCB, Cast Iron	01
10	Hand Wheel Nut	ASTM A216 Gr. WCB, Cast Iron	01

NOTE:

Due to continuous development higher class and sizes will be available upon request