

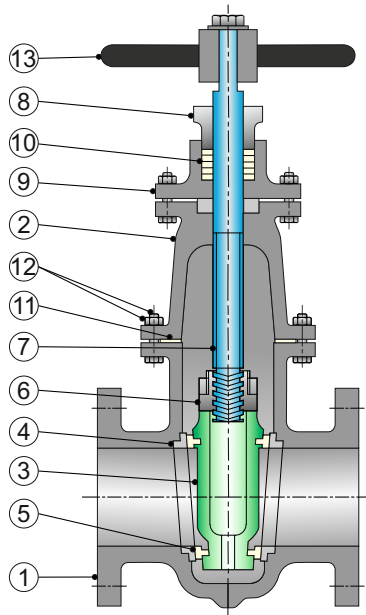

### DESIGN FEATURES:

Manufacturing Std.	: IS 14846
Testing & Inspection Std.	: IS 14846
Face to Face & End to End	: IS 14846
End Flange Dimension	: IS 1538 (Table 4 & 6)
Pressure Rating	: ASME B16.34
Operation	: Manual & Actuator
Class	: PN 1.0, PN 1.6, #150 & #300
Size Range	: 40mm to 600mm

### TYPE LGAC - 200



### MATERIALS OF CONSTRUCTION

Part No.	Description	Material	Qty.
1	Body	ASTM A216 Gr. WCB, A351 CF8/CF8M, Cast Iron	01
2	Bonnet	ASTM A216 Gr. WCB, A351 CF8/CF8M, Cast Iron	01
3	Wedge	AISI 410 (13% Cr.), A351 CF8/CF8M/CF3/CF3M	01
4	Body Ring	Bronze IS 318 LTB2	02
5	Wedge Ring	Bronze IS 318 LTB2	02
6	Wedge Nut	Bronze IS 318 LTB2	01
7	Non-Rising Stem	AISI 410, A351 CF8/CF8M/CF3/CF3M	01
8	Gland	AISI 410, A351 CF8/CF8M/CF3/CF3M	01
9	Stuffing Box	ASTM A216 Gr. WCB, A351 CF8/CF8M, Cast Iron	01
10	Stem Packing	JUTE & HEMP	Req.
11	Bonnet Gasket	Rubber IS 638 Type B	01
12	Bonnet Bolts & Nuts	CS IS 1363 CL-4.6 / IS 1367 CL-4.0	Req.
13	Hand Wheel	ASTM A216 Gr. WCB, Cast Iron	01

### NOTE:

Due to continuous development higher class cr. and sizes will be available upon request