

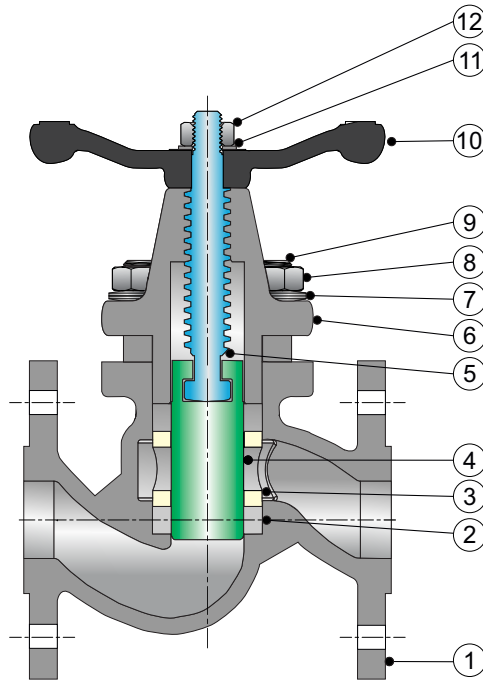

DESIGN FEATURES

Manufacturing Std.	: ASME B16.34 / EN 12516-2
Testing & Inspection Std.	: API 598
End Flange Dimension	: ASME B16.5
End to End	: ASME B16.10
Operation	: Manual
Class	: #150, #300 & #800
Size Range	: 50mm to 250mm

TYPE LPTC - 550



MATERIALS OF CONSTRUCTION

Part No.	Description	Material	Qty.
1	Body	ASTM A216 Gr. WCB	01
2	Seat Ring	ASTM A216 Gr. WCB	01
3	Lantern Ring	AISI 410 + H.F	01
4	Piston	AISI 304 + H.F	01
5	Stem	AISI 410, CA 15	01
6	Bonnet	AISI 410	01
7	Belleville Washer	Spring Steel	01
8	Nut	AISI 304	Req.
9	Stud	SS 304	Req.
10	Hand Wheel	AISI 304 , CF8	01
11	Hand Wheel Washer	Spring Steel	01
12	Stem Nut	AISI 410	01

NOTE:

Due to continuous development higher class and sizes will be available upon request