

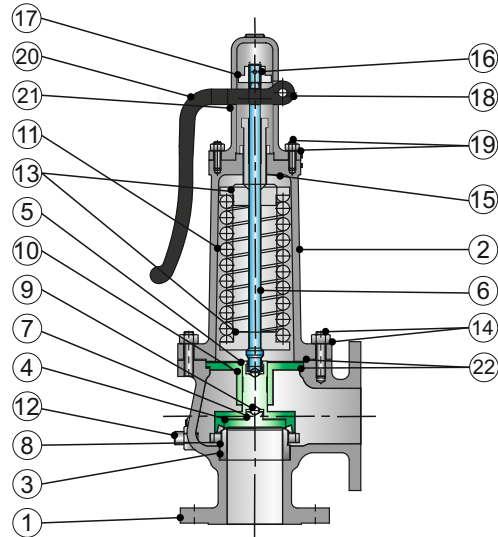

TYPE LSAC - 475

DESIGN FEATURES:

- Manufacturing Std. : API 526
- Testing & Inspection Std. : API 527
- End Flange Dimension : Inlet Flange as per BS 10 Table 'H'
Inlet Flange as per BS 10 Table 'F'
- Size Range : 25mm to 100mm



MATERIALS OF CONSTRUCTION

Part No.	Description	Material	Qty.
1	Body	ASTM A216 Gr. WCB	01
2	Bonnet	ASTM A216 Gr. WCB	01
3	Seat Ring	AISI 410 + H.F	01
4	Disc	AISI 304 + H.F	01
5	Disc Guide	AISI 410, CA 15	01
6	Stem	AISI 410	01
7	Disc Retainer	Spring Steel	01
8	Blow Down Ring	AISI 304	01
9	Balls	SS 304	02
10	Guide Plate	AISI 304 , CF8	01
11	Spring	Spring Steel	01
12	Locking Screw	AISI 410	01
13	Spring Washers	Carbon Steel	02
14	Body Stud & Nut	ASTM A193 Gr. B7 & ASTM A194 Gr. 2H	Req.
15	Adj. Screw & Lock Nut	AISI 410	01
16	Cottor Pin	Carbon Steel	01
17	Lock Nut	Carbon Steel	01
18	Lever Pin	Carbon Steel	01
19	Cap Stud & Nut	Carbon Steel	04
20	Lever	S.G. Iron	01
21	Cap	CI IS 210 Gr. FG 200, S.G. Iron	01
22	Gasket	CAF, Soft Iron	02

NOTE:

Due to continuous development higher class and sizes will be available upon request