

DESIGN FEATURES:

- Manufacturing Std. : BS 1873
- Testing & Inspection Std. : API 598 / BS 5146
- Face to Face & End to End : ASME B16.10
- End Flange Dimension : ASME B16.5 / BS 1560
- Pressure Rating : ASME B16.34
- Class : #150, #300, #600, #900, & #1500
- Size Range : 40mm to 600mm

TYPE LSWC - 275

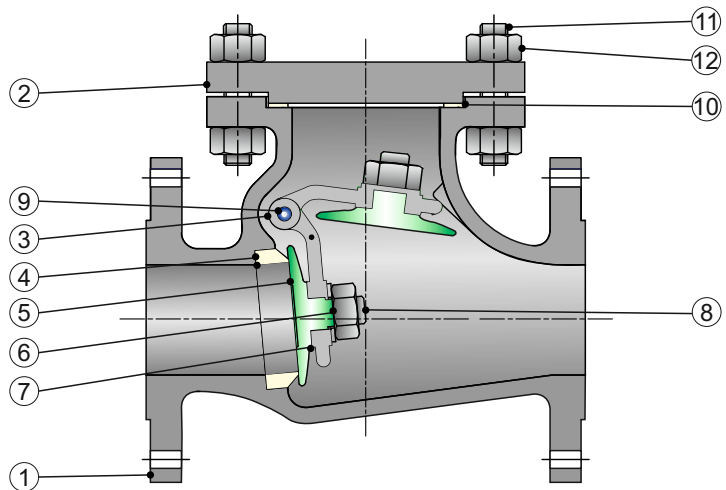

MATERIALS OF CONSTRUCTION

Part No.	Description	Material	Qty.
1	Body	ASTM A216 Gr. WCB	01
2	Cover	ASTM A216 Gr. WCB	01
3	Hinge	ASTM A216 Gr. WCB	01
4	Seal Ring	AISI 410, ASTM A217 Gr. Ca15	01
5	Disc	ASTM A217 Gr. Ca15, WCB + 13% Cr. Facing	01
6	Disc Returning Nut	AISI 304	01
7	Disc Washer	AISI 304, AISI 410	01
8	Cotter Pin	AISI 304	01
9	Hinge Pin	AISI 410	01
10	Cover Gasket	Spiral Wound, CAF	01
11	Cover Stud	ASTM A193 Gr. B7	Req.
12	Cover Nut	ASTM A194 Gr. 2H	Req.

NOTE:

Due to continuous development higher class and sizes will be available upon request